

GRD 150

Scambiatori Serie GR S/D

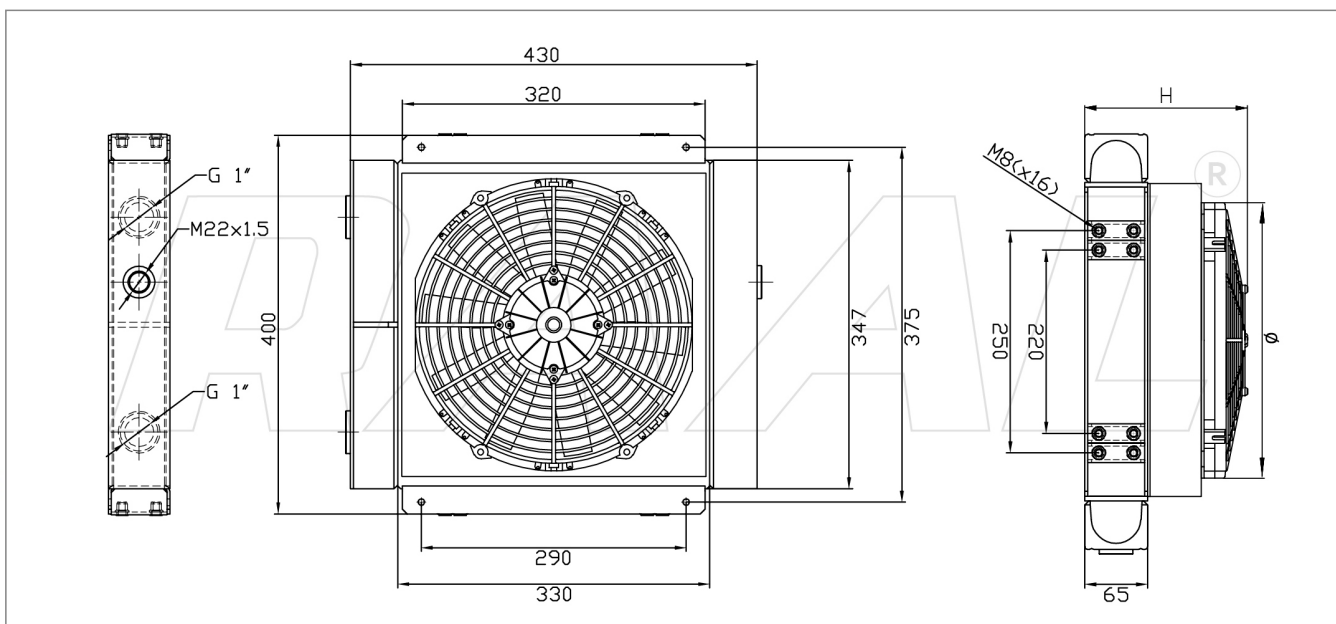

Gamma Scambiatori

Codice Prodotto	Tipologia Allestimento	Ingombro H	Ventola diam.	Portata Ventola m3/h	M.R. dm3	Potenza Assorbita
RU0100660000	NUDO	65	-	-	7,44	-
RU0100660011	12V Asp.	230	305	1839	7,44	16,5 A
RU0100660012	12V Soff.	230	305	1736	7,44	14,9 A
RU0100660021	24V Asp.	230	305	2161	7,44	10,3 A
RU0100660022	24V Soff.	230	305	2050	7,44	9,1 A
RU0100660031 [*]	230V-50/60Hz Asp.	195	300	3745	7,44	1,55 A
RU0100660032 [*]	230V-50/60Hz Soff.	195	300	3745	7,44	1,55 A
RU0100660041	230/400V-50/60Hz 3FN Asp.	195	300	3350	7,44	0,48 A
RU0100660042	230/400V-50/60Hz 3FN Soff.	195	300	3350	7,44	0,48 A
RU0100660051	Pred. Hydraulic. Asp. (Supp. G2)	245	300	3080	7,44	0,41 kW
RU0100660052	Pred. Hydraulic. Soff. (Supp. G2)	245	300	3080	7,44	0,41 kW

[*] Nei modelli MONOFASE (*31/*32), a richiesta TERMOSTATO REGOLABILE 0-90°.

Dati Tecnici

Range Minimo

Kw 15 : 15 lt

Range Massimo

Kw 25 : 70 lt

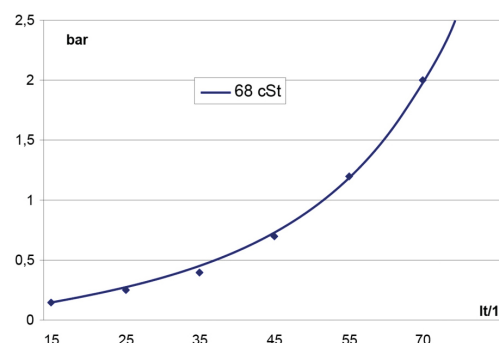
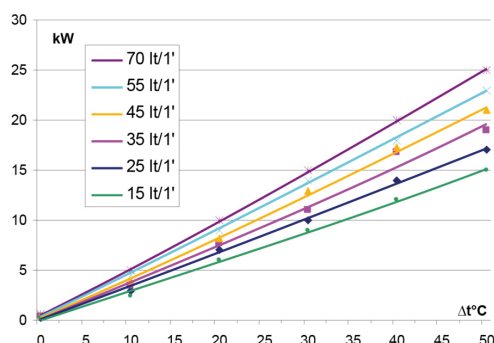

Le dimensioni di ingombro e le caratteristiche tecniche sono da considerarsi indicative, trattandosi di prodotti standard in continua evoluzione.

