

VTS 150

Oil Coolers VT Series

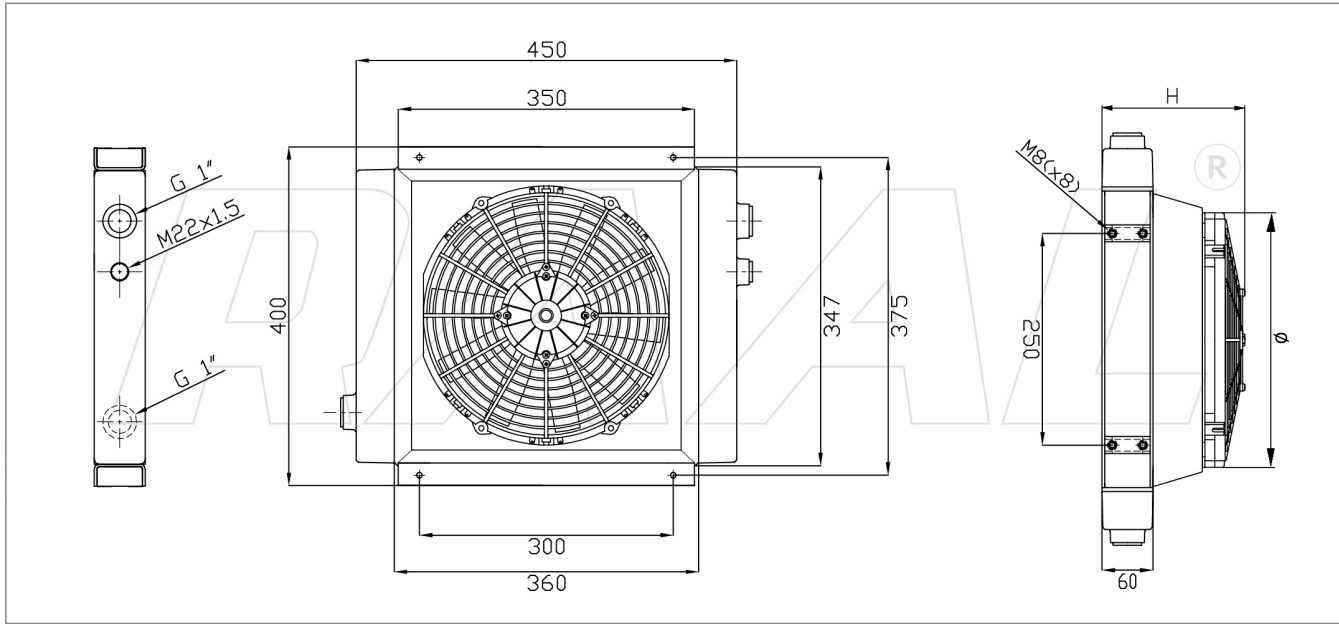

Gamma Oil Coolers

Product Code	Type of Setting	Overall H	Fan diameter	Fan Power m3/h	M.R. dm3	Power Consumpt.
RUV100650000	UNCOVERED	60	-	-	7,87	-
RUV100650011	12V Suct.	225	305	1839	7,87	16,5 A
RUV100650012	12V Blow.	225	305	1736	7,87	14,9 A
RUV100650021	24V Suct.	225	305	2161	7,87	10,3 A
RUV100650022	24V Blow.	225	305	2050	7,87	9,1 A
RUV100650031	230V-50/60Hz Suct.	190	300	3745	7,87	1,55 A
RUV100650032	230V-50/60Hz Blow.	190	300	3745	7,87	1,55 A
RUV100650041	230/400V-50/60Hz 3FN Suct.	190	300	3350	7,87	0,48 A
RUV100650042	230/400V-50/60Hz 3FN Blow.	190	300	3350	7,87	0,48 A
RUV100650051	Pred. Hydraulic. Suct. (Supp. G2)	240	300	3080	7,87	0,41 kW
RUV100650052	Pred. Hydraulic. Blow. (Supp. G2)	240	300	3080	7,87	0,41 kW

Technical Specification

Minimum Range

Kw 15 : 30 lt

Maximum Range

Kw 25 : 140 lt

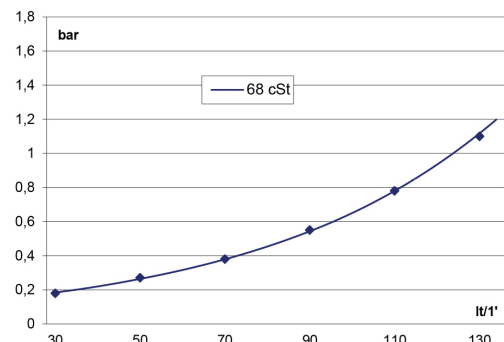
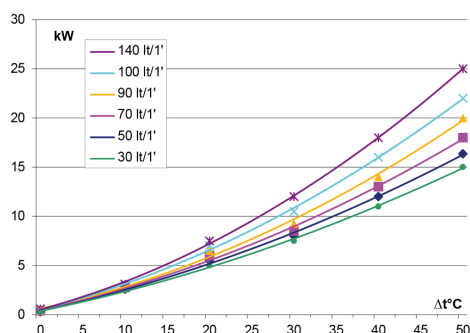

The overall dimensions and the technical characteristics are to be considered indicative, dealing with standard products in constant evolution.

