

VTS 210

Oil Coolers VT Series

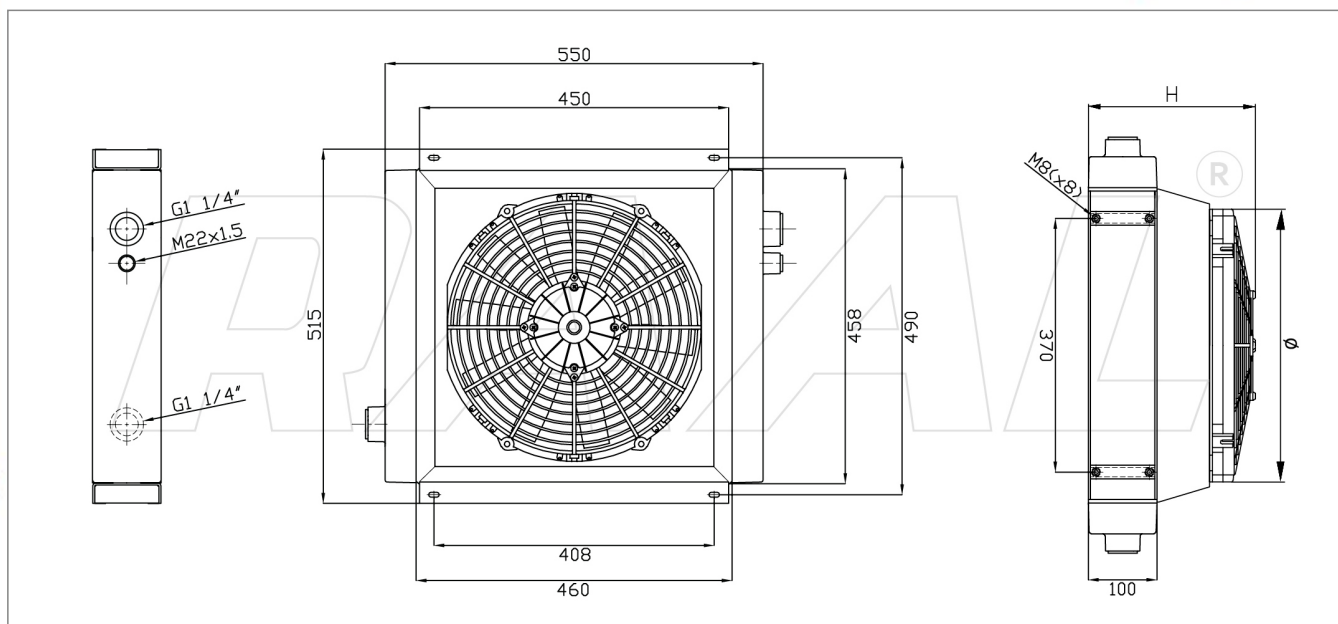

Gamma Oil Coolers

Product Code	Type of Setting	Overall H	Fan diameter	Fan Power m3/h	M.R. dm3	Power Consumpt.
RUV100710000	UNCOVERED	100	-	-	19,67	-
RUV100710011	12V Suct.	265	385	2212	19,67	16,0 A
RUV100710012	12V Blow.	265	385	2412	19,67	16,2 A
RUV100710021	24V Suct.	265	385	2577	19,67	9,3 A
RUV100710022	24V Blow.	265	385	2609	19,67	9,0 A
RUV100710031	230V-50/60Hz Suct.	265	400	4950	19,67	1,06 A
RUV100710032	230V-50/60Hz Blow.	265	400	4950	19,67	1,06 A
RUV100710041	230/400V-50/60Hz 3FN Suct.	265	400	4615	19,67	0,39 A
RUV100710042	230/400V-50/60Hz 3FN Blow.	265	400	4615	19,67	0,39 A
RUV100710051	Pred. Hydraulic. Suct. (Supp. G2)	285	400	7050	19,67	1,5 kW
RUV100710052	Pred. Hydraulic. Blow. (Supp. G2)	285	400	7050	19,67	1,5 kW

Technical Specification

Minimum Range

Kw 20 : 80 lt

Maximum Range

Kw 42 : 260 lt

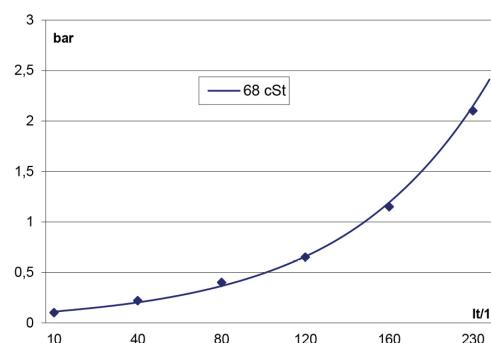
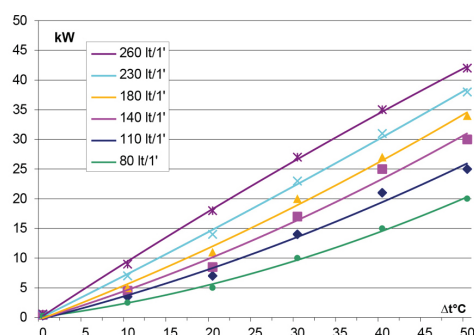

The overall dimensions and the technical characteristics are to be considered indicative, dealing with standard products in constant evolution.

