

GRS 50

Oil Coolers GR S/D Series

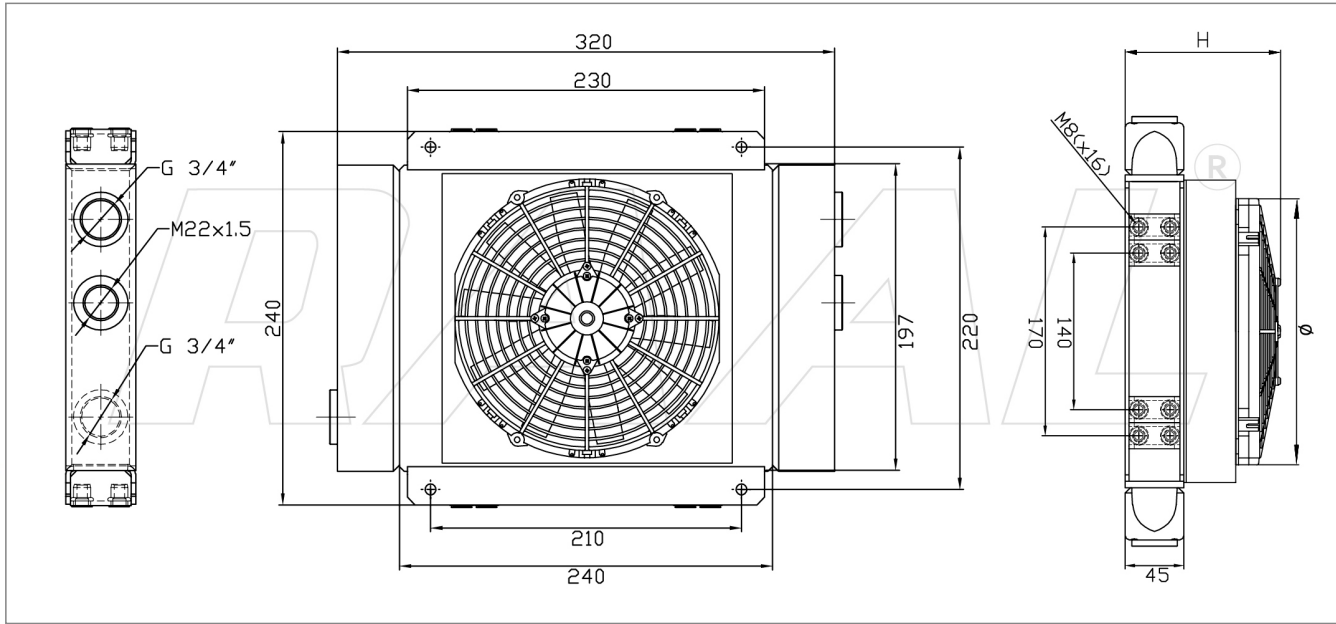

Gamma Oil Coolers

Product Code	Type of Setting	Overall H	Fan diameter	Fan Power m3/h	M.R. dm3	Power Consumpt.
RU0100610000	UNCOVERED	45	-	-	2,13	-
RU0100610011	12V Suct.	140	190	446	2,13	6,4 A
RU0100610012	12V Blow.	140	190	497	2,13	6,4 A
RU0100610021	24V Suct.	140	190	419	2,13	2,8 A
RU0100610022	24V Blow.	140	190	505	2,13	3,3 A
RU0100610031 [*]	230V-50/60Hz Suct.	135	200	1025	2,13	0,34 A
RU0100610032 [*]	230V-50/60Hz Blow.	135	200	1025	2,13	0,34 A
RU0100610041	230/400V-50/60Hz 3FN Suct.	135	200	1020	2,13	0,13 A
RU0100610042	230/400V-50/60Hz 3FN Blow.	135	200	1020	2,13	0,13 A
RU0100610051	Pred. Hydraulic. Suct. (Supp. G1)	185	195	958	2,13	0,7 kW
RU0100610052	Pred. Hydraulic. Blow. (Supp. G1)	185	195	958	2,13	0,7 kW

[*] In SINGLE PHASE models (*31/*32), ADJUSTABLE THERMOSTAT 0-90° on request.

Technical Specification

Minimum Range

Kw 3 : 10 lt

Maximum Range

Kw 6,3 : 80 lt

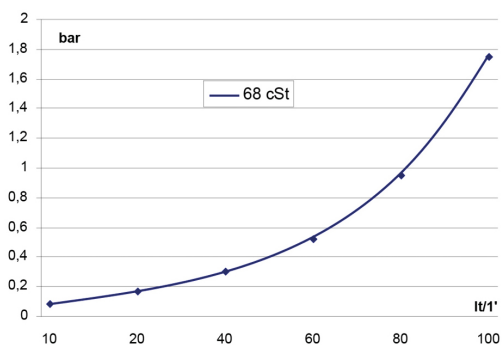
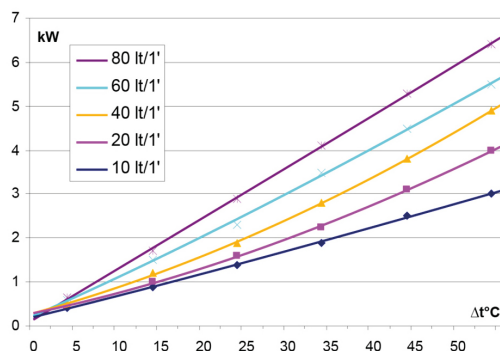

The overall dimensions and the technical characteristics are to be considered indicative, dealing with standard products in constant evolution.

